

SILICON UPDATE

Tom Cantrell

In the quest to cram everything on a single chip, the next step is to integrate these nondigital support functions onto the MCU, creating what's best described as a mixed-signal micro.

Examples of the trend abound. Microchip made a deal with Seattle Silicon and introduced the PIC16HV540, which includes a built-in voltage regulator (use any 6–12-V battery or wall-mount supply) and high-voltage (15 V) I/O for direct connect to sensors and relays.

The trend also presents an opportunity for new suppliers to enter the MCU market. For instance, Analog Devices leveraged their mixed-signal know-how with the AduC812, which combines a fast (200 kHz) eight-channel 12-bit ADC, two-channel 12-bit DAC, and flash-based 8051 MCU core.

It's not hard to imagine other mixed-signal leaders making a move. So, I was excited, but not surprised, when I heard Maxim was working on a processor.

For those (presumably few) of you not familiar with the company, Maxim has done well by offering a huge selection of mixed-signal problem solvers including ADCs, DACs, op-amps, supervisors, transceivers, and the like.

This being their first showing in the processing theatre, the MAX1460 is best described as a smart ADC because

Maximicro



Tom says that the MAX1460 has lots of talent

but its processor will never be a star. Why? Because it doesn't aspire to be. That's the innovative twist he applauds on Maxim's first step into the micro market.



as in a movie, the big star chips (like micros and memories) garner all the attention and adulation. But although they're given little more than a few seconds of scrolling fine print in the credits, others are just as important when it comes to getting the film in the can.

The headliners rely on a supporting cast of chips to handle glue logic and

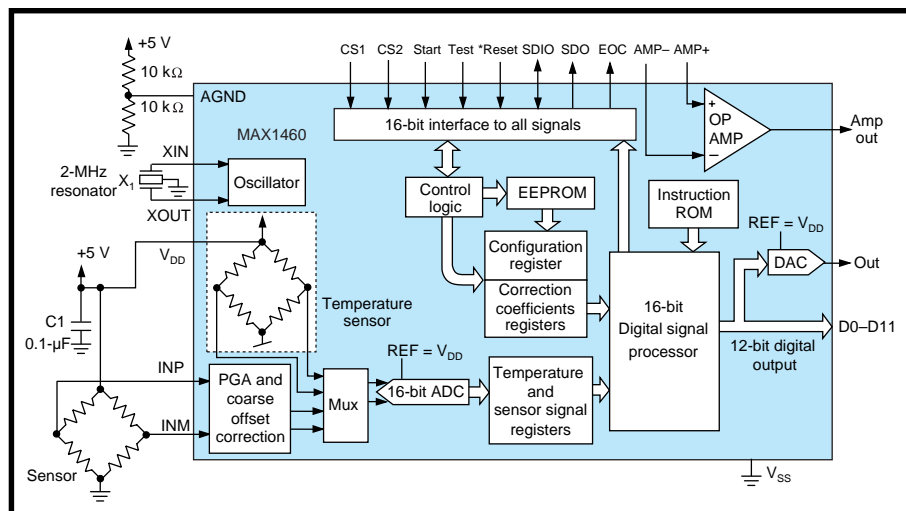

Figure 1—The MAX1460 combines everything needed to accommodate a variety of bridge-type sensors. Major integrated functions include a programmable gain amp (PGA), 16-bit ADC, temp sensor, and 16-bit processor.

the on-chip 16-bit processor isn't user programmable. The processor isn't the star; it plays a supporting role.

Figure 1 gives you a backstage look. The on-chip processor is one link in a signal chain that includes a programmable gain amp, 16-bit ADC, temperature sensor, 12-bit DAC, and op-amp.

The micro is described as a RISC or DSP, presumably combining aspects of both (not that there's much difference anymore). At this point, the details of the architecture and on-chip ROM code haven't been disclosed, although much can be inferred by the functions they perform.

PIEZO DE RESISTANCE

To get a better idea of what the MAX1460 is, let's look at where it came from and what it's supposed to do.

The MAX1460 is designed to act as a signal-conditioning front end for a variety of sensors, especially those based on the classic Wheatstone bridge. The Wheatstone-bridge concept exploits the fact that physical energy (tension or compression) causes a change in resistance detected as a voltage differential between the two legs of the bridge.

The Wheatstone bridge is versatile. Use gravity as the physical input and you've got a scale. Turn it sideways and it's an accelerometer. Mechanically connect it, and voilà, a strain gauge. Use the bridge as a diaphragm and it detects pressure, level, and flow.

That's the good news. The bad news is extremely low-level output that is hard to detect and easily swamped by ambient electrical interference.

A typical piezo-resistive bridge sensor



Photo 1—They call it a smart ADC, and the MAX1460 arguably represents Maxim's first entry into the micro market.

may be able to generate only 20 mV or so per volt of excitation. In a 5-V system, that means the peak output is 100 mV, which even at meager 8-bit resolution requires the ability to detect low-level signals down to hundreds of microvolts per least-significant bit. Push for 12 bits and you're talking nanovolts!

Resistors also react to temperature (i.e., thermistor), which is nice when that's what you want to do. Otherwise, it's a pain.

An uncompensated sensor may exhibit thermal errors on the order of 10, 20, or even 30% of full-scale output (FSO) including significant (e.g., 5% FSO) nonlinearity. Without temperature compensation, there's no need to worry about A/D resolution because even a few bits of accuracy will be tough to obtain.

You know the drill. Get some op-amps, a temp sensor (to compensate), ADC, MCU, and a grab bag of discretes, then have at it. Amplify the input and remove any offset, compensate (both gain and offset) for temperature, and output the digital result.

Earlier parts like the MAX1457 and '58 (see Figure 2), put together a few parts of the puzzle. The main differ-

ence is that the '57 uses a relatively large (128 × 16) external EEPROM to store temperature compensation coefficients and the '58 has a smaller EEPROM (8 × 16) on chip.

The different size of the EEPROM reflects a fundamental difference in the '57's and '58's approach to compensation. It starts by realizing that the goal of compensation is to come up with curves that cancel the sensor's output and offset thermal error curves.

Every programmer knows there are two ways to generate a curve. Either come up with an equation that defines the curve, or use a table lookup. That's the difference between the '57 and '58.

The '57 relies on its larger EEPROM to store a table of output and offset compensations corresponding with up to 120 temperature points. This setup enables the output to be fine-tuned across the entire temperature range, yielding excellent 0.1% accuracy.

Meanwhile, the '58 (essentially an analog computer hardwired to execute one calculation) uses an equation incorporating error coefficients. An equation of only a few terms takes up a lot less room in memory than a table, hence the '58's smaller EEPROM.

But, a simple equation usually does not perfectly fit a real-world curve, so the '58's accuracy (1%) isn't as good as the '57's. Still, 1% is good compared to the 10–20% or greater error of an uncompensated sensor.

Although a big improvement over rolling your own, the '57 and '58 are still analog from the system designer's point of view. Not only do you have to come up with an ADC and the software to babysit it, you're likely to encounter problems getting the analog signal from here to there, especially in a high-temperature or otherwise harsh environments where the sensor and controller are physically separated.

LITTLE SIGNAL, BIG BITS

Enter the '1460. By adding the ADC and micro, the '1460 puts everything under one roof, inputting a tiny signal from the bridge and outputting accurate

Coefficient	Register address	Function	Range	Format
Gain	1	Gain correction	−32,768 to +32767	Integer
G ₁	2	Linear TC gain	−1.0 to +0.99997	Fraction
G ₂	3	Quadratic TC gain	−1.0 to +0.99997	Fraction
Of ₀	4	Offset correction	−1.0 to +0.99997	Fraction
Of ₁	5	Linear TC offset	−1.0 to +0.99997	Fraction
Of ₂	6	Quadratic TC offset	−1.0 to +0.99997	Fraction
D _{OFF}	7	Output midscale pedestal	−32,768 to +32767	Integer

Table 1—The key calculation performed by the on-chip processor compensates sensor offset and gain for temperature by using sensor-dependent correction coefficients.

Command	Hex Code
Write a calibration coefficient into a DSP register	1 hex
Block-erase the entire EEPROM (write 0 to all 128 bits)	4 hex
Write 1 to a single EEPROM bit	2 hex
NOOP (no operation)	0 hex
Start conversion: registers are not updated with EEPROM values. SDIO and SDO are enabled as DSP outputs	8 hex
Start conversion: registers are updated with EEPROM values. SDIO and SDO are enabled as DSP outputs	A hex
Start conversion: registers are not updated with EEPROM values. SDIO and SDO are disabled	C hex
Start conversion: registers are updated with EEPROM values. SDIO and SDO are disabled	E hex
Reserved	3, 5, 6, 7, 9, B, D, F hex

Table 2—Calibration and EEPROM programming is carried out by a host system that issues commands to the on-chip processor and monitors operation via the SDIO and SDO pins.

'1460s can reside on a common bus. Conversion can also be initiated with the START pin. This feature is useful if the default 35-ms sensor warm-up time is insufficient. There's a repeat mode that automatically reinitiates conversion (max. sample rate is 15 Hz).

SERIAL SETUP

Using the MAX1460 is easy. But, setting it up (i.e., determining the proper calibration coefficients and programming them into the on-chip EEPROM) is another story.

With the TEST pin asserted, two other pins (SDIO and SDO) provide access to the chip's inner workings. The first gotcha is that in Test mode,

(0.1%, 12 bit) 1s and 0s. The operating principle is exactly the same as before, but now most of the details and sensitive analog signals are handled on chip.

The design is ratiometric (i.e., relative to supply voltage) with input centered around a virtual ground, obtained by connecting 10-kΩ pull-up and pull-down resistors to AGND. Maxim recommends avoiding the extremes of the input range for best signal-to-noise ratio (SNR). So, it's best to try to keep the input between 1 and 4 V rather than the full-scale 0–5 V.

The first step is coarse amplification ($\times 46$, $\times 61$, $\times 77$, or $\times 93$) and offset correction (eight selections) to get dynamic range into the ballpark. The output is a differential voltage between $-V_{DD}$ and $+V_{DD}$ that, post-A/D conversion, is interpreted as an integer value between -32768 and $+32767$ or, for correction coefficients, a fraction between -1.0 and $+0.99997$.

Once digitized by the 16-bit ADC, the coarse-adjusted input and on-chip temperature-sensor reading are fed to the processor. Although the output is only 12 bits, 16 bits of resolution are required here to prevent quantization and rounding errors from polluting the final output.

The other set of processor inputs comes from the correction-coefficient registers in Table 1 that reflect the offset and output specs for a particular sensor, including thermal characteristics.

With digitized input and temp and the correction coefficients in hand, the processor executes $Output = Gain(1 + G_1T + G_2T^2)(Signal + Of_0 + Of_1T + Of_2T^2) + D_{OFF}$ to generate an output that compensates the sensor's offset and gain (see Figure 3).

Gain and D_{OFF} deal with the basic gain and offset of the sensor and G_1 , G_2 , Of_1 , and Of_2 handle linear and non-linear components of thermal compensation. Essentially, the MAX1460 processor does in software what the earlier parts did with analog circuits.

Once the calculation is complete, the 12-bit result is output in parallel on the D0–D11 pins. It's simultaneously delivered as a bitstream on the OUT pin. Feeding OUT back through the spare on-chip op-amp and adding a few discretes permits a high-level (rail-to-rail) analog voltage or 4–20-mA output to be generated.

It may seem odd for a sensor to go both ways (i.e., analog and digital outputs), but often, industrial designers require legacy analog capability to help smooth the migration of their customers and installed equipment base to fully digital designs.

From the system designer's perspective, MAX1460 operation is simple. Just power up and the signal is acquired and processed, and 67 ms later the outputs (D0–D11, OUT) are updated and the EOC pin signals completion. Two chip-select pins (CS1 and CS2) condition all digital I/Os, so multiple

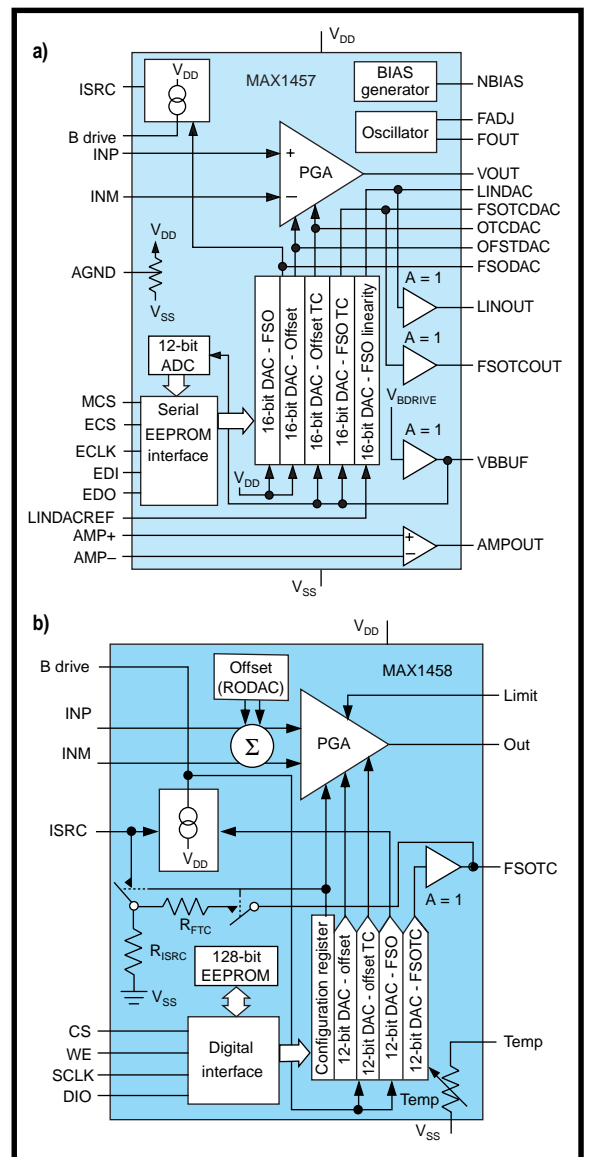
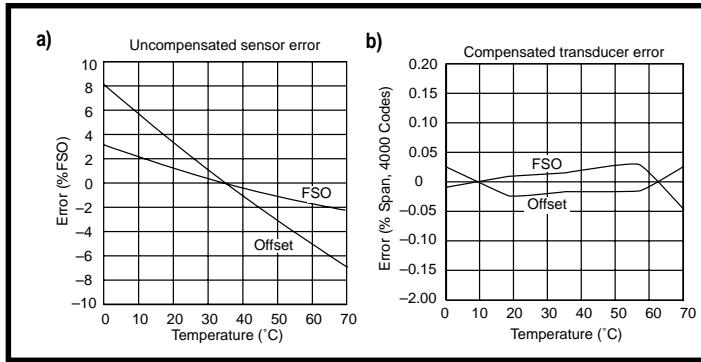

Figure 2—Earlier Maxim parts, the MAX1457 (a) and MAX1458 (b), targeted the same bridge sensor applications but required support from an external ADC and micro.

Figure 3—Once calibrated, the output accuracy across temperature of the MAX1460+ sensor pair (a) is dramatically improved compared to the uncompensated sensor (b).



the host system is responsible for providing a 2-MHz 50% duty-cycle clock on XIN that not only clocks transfers on SDIO and SDO but also runs the chip. According to the designers, the clock could probably range from about 1 to 3 MHz before it impacts conversion accuracy, but the datasheet says 2 MHz, period.

Calibration for a particular MAX1460 and sensor pair involves determining the appropriate values for the configuration and correction-coefficient registers. The idea is to operate the sensor and MAX1460 pair under various temperature (low, medium, and high) and input-excitation (low and high) conditions to gather enough data points to fit a curve using the output equation and correction coefficients.

To communicate with the chip, the host system issues commands (see Table 2) and monitors processor activity and results via SDIO and SDO. The processor reveals the contents of the accumulator (S), the 8-bit program counter (P), and the 8-bit instruction it's currently executing (PS). A new instruction and corresponding 32 bits of status (S, P, and PS) are delivered every 16 clock cycles.

After issuing the start-conversion command, the host looks for the appearance of certain opcodes on SDIO to catch the conversion result on SDO exactly 130,586 XIN clock cycles later (i.e., 65.293 ms). Remember that all of this happens at 2 MHz.

Once the sensor-specific configuration and calibration is determined, it's time to burn it into the 128-bit (8×16) EEPROM. This exercise calls for a different (125 kHz) clock and multiple commands to program each bit individually.

I don't see any commands to read the EEPROM; only one to erase it. Not

sure how comfortable I am with the concept of a write-only memory. On the other hand, it offers security to anyone worried about having their coefficients ripped off. I suspect there's a way to read the EEPROM, but it's not in the datasheet.

Once programmed and put back into service (TEST deasserted), things get simple again. After powerup, the MAX1460 automatically loads the EEPROM contents into the configuration and correction-coefficient registers and does its thing.

EV WAY OUT

The fact that the setup procedure is nontrivial would seem to dampen aspirations for self-calibrating designs that could adapt over time, perhaps to compensate for sensor aging or environmental changes.

To their credit, Maxim appears to disclose enough details to enable you to support in-system self-reconfiguration. But, they clearly expect that reprogramming the EEPROM won't be done often and will be handled by a test system rather than logic built into the application.

To that end, they offer the MAX1460 evaluation kit. It includes an EV board with the '1460 and sample pressure sensor, an interface board that connects to a PC parallel port, Windows software that walks the user through calibration, and EEPROM programming and documentation.

Keep in mind that calibration for a custom-matched MAX1460 and sensor pair is tedious. It may take a couple hours because the sensor has to soak for about 30 min. at each temperature. Thus, the software assist that Maxim provides to automate the process is a welcome addition.

Although it's targeted at a fairly narrow niche, I find the MAX1460 intriguing in its implications for the bigger picture. It provides more evidence of the trend towards mixed-signal micros and smart sensors.

The Maxim folks I spoke with indicated that opportunities related to IEEE 1451.2 (the digital sensor interface discussed in *INK* 104) are under review.

Finally, Maxim's entry into the micro marketplace, albeit rather indirectly, may portend exciting times for MCU customers and competitors. ☒

Tom Cantrell has been working on chip, board, and systems design and marketing in Silicon Valley for more than ten years. You may reach him by e-mail at tom.cantrell@circuitcellar.com, by telephone at (510) 657-0264, or by fax at (510) 657-5441.

SOURCES

MAX1457, '1458, '1460

Maxim Integrated Products
(408) 737-7600
Fax: (408) 737-7194
www.maxim-ic.com

PIC16HV540

Microchip Technology, Inc.
(602) 786-7200
Fax: (602) 899-9210
www.microchip.com

AduC812

Analog Devices
(617) 329-4700
Fax: (617) 329-1241
www.analog.com

©Circuit Cellar *INK*, the Computer Applications Journal. Reprinted by permission. For subscription information, call (860) 875-2199 or subscribe@circuitcellar.com